

4NR 4-Channel Thermistor Interface 6000-25-TR



FEATURES

- 4-channel 10k ohm thermistor interface (alternative thermistor interfaces optional)
- 12-bit Analog to Digital Conversion
- Transmits unique ID and thermistor value
- RS485 multi-drop interface
- Sequentially transmits data from each of 4 channels
- Very small (2.5" x 2.0" X 1.0") ABS Enclosure
- CRC-16 checked Status, ID, and thermistor data
- Low Cost
- 2.5" X 2" X 1" ABS enclosures

DESCRIPTION

The Point Sensor 4NR transmitter is a powered 10K ohm thermistor interface with RS-485 interface. At predetermined time intervals the clock will wake up the onboard microprocessor and thermistor data is read from a 12-bit analog-to-digital converter. This information is combined with a unique serial ID, CRC-16 error check and transmitted in a very short data packet via the RS-485 interface

The electronics are coated with a conformal material that provides a moisture barrier against condensation. Submersion in water is not recommended. A button on the top of the ABS cover permits a user to activate the service switch. When the service switch is held a data transmission occurs immediately and a special mark is introduced in the ID field of the transmitted data for the selected channel (hold pushbutton to generate service packets for the individual channels with LED feedback). The built-in LED provides feedback for when standard data is transmitted and indication of which channel is producing the service packet.

Transmission rate	10-17 seconds random (alternates channel every 3-4 seconds)
Dimensions (enclosure)	2.5 W X 2.0 H X 1.0 D (inches)
Weight	1.5 oz.
Operating Temperature	-40° to 85° C
Input	10K ohm thermistor (alternative thermistors available)
Humidity	0% to 90% non-condensing

Point Six Wireless
Unique, High Value Wireless Solutions

Packet-Data Specification

Thermistor Sensor Data Format

“Thermistor” (57/56)

IDSSSSSSSSSSSSSSSSSSAAAACCCCKK<CR>

Note: All fields are in ASCII Hex

“ID”

This field is the device type and mode indicator, the 57 or 56 indicates that this is a Thermistor analog transmitter; 56 indicates the transmitter is in service mode.

“SSSSSSSSSSSSSSSSSS”

This field is the 64 bit unique serial number of the Thermistor sensor.

“AAAA”

This is the analog data field. This field is 16 bits stored MSB first (bits 15-8) and LSB last (bits 7-0) from left to right. This is a value of 0-32767 for 0-fullscale. Conversion is dependant on thermistor type and termination specified (default termination is 10,000 Ohm.)

“CCCC”

This field is the CRC-16 error check as was originally received and checked. This CRC is over the first 11 bytes of the packet starting with the device type and ending with but not including CRC-16.

“KK”

This field is the mod 256 sum of all the binary data values as represented by the ASCII hex values in the response but does not include the <CR>.

4NR Thermistor Topology Examples

Wired link between 4NR and Point Manager

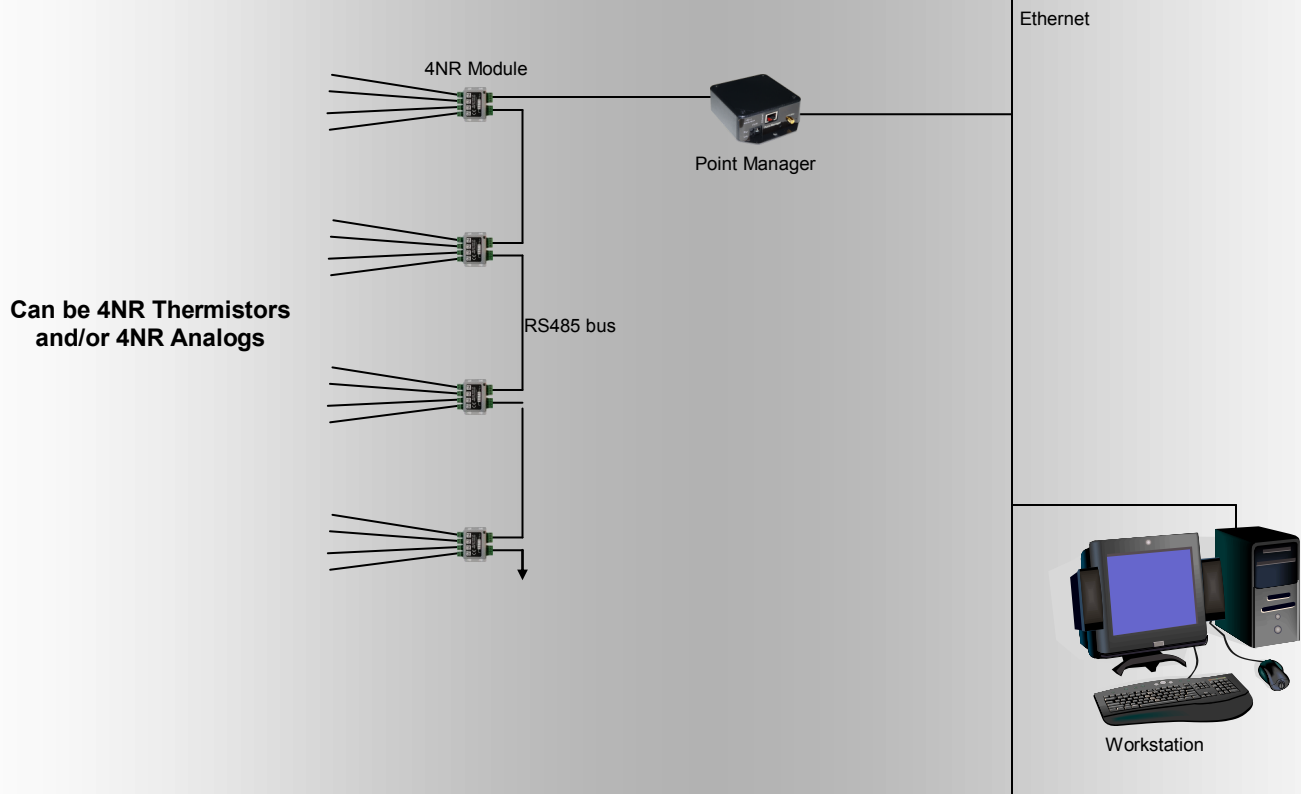

Wireless Link between 4NR and Point Manager

